

Aluminium electrolytic capacitors Axial Standard

030/031 AS

FEATURES

- Polarized aluminium electrolytic capacitors, non-solid
- Axial leads, cylindrical aluminium case, insulated with a blue sleeve
- Taped version available for automatic insertion
- Charge and discharge proof
- Useful life: 3000 hours at 85 °C (case ØD = 3.3 mm: 1500 hours)
- Standard dimensions.

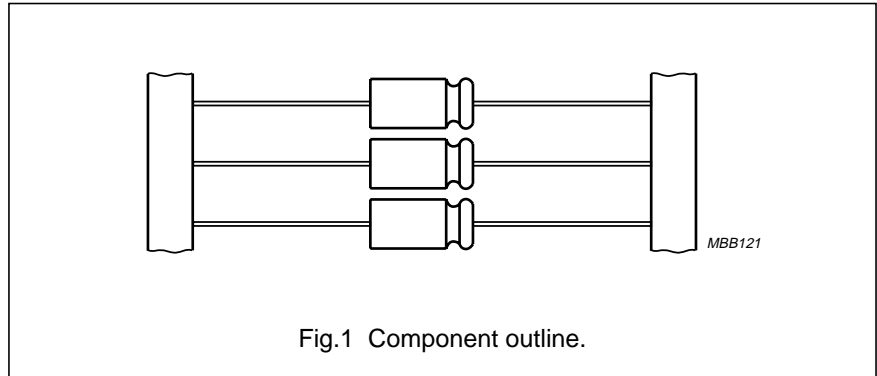

APPLICATIONS

- General purpose and industrial, automotive, telecommunication, audio-video
- Coupling, decoupling, timing, smoothing, filtering, buffering in SMPS
- Boards with restricted mounting height, vibration and shock resistant.

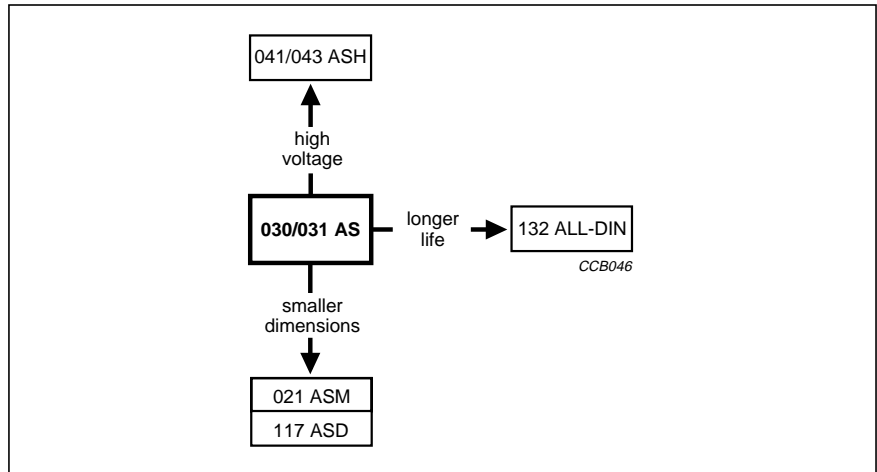

QUICK REFERENCE DATA

DESCRIPTION	VALUE	
Case sizes (ØD _{nom} × L _{nom} in mm)	3.3 × 11	4.5 × 10 to 10 × 25
Rated capacitance range, C _R	0.47 to 1000 µF	
Tolerance on C _R	-10 to +50%	
Rated voltage range, U _R	6.3 to 100 V	
Category temperature range	-40 to +85 °C	
Endurance test at 85 °C	1000 hours	2000 hours
Useful life at 85 °C	1500 hours	3000 hours
Useful life at 40 °C, 1.4 × I _R applied	40000 hours	80000 hours
Shelf life at 0 V, 85 °C	500 hours	
Based on sectional specification	IEC 384-4/CECC 30300	
Climatic category IEC 68	40/085/56	

Aluminium electrolytic capacitors

Axial Standard

030/031 AS

Selection chart for C_R , U_R and relevant nominal case sizes ($\varnothing D \times L$ in mm)

Preferred types in **bold**.

C_R (μF)	U_R (V)						
	6.3	10	16	25	40	63	100
0.47	–	–	–	–	–	–	4.5 × 10
1.0	–	–	–	–	–	4.5 × 10	4.5 × 10
	–	–	–	–	–	3.3 × 11	–
2.2	–	–	–	–	3.3 × 11	4.5 × 10	4.5 × 10
3.3	–	–	–	–	–	4.5 × 10	4.5 × 10
4.7	–	–	3.3 × 11	–	–	4.5 × 10	6 × 10
6.8	–	–	–	–	–	4.5 × 10	6 × 10
10	3.3 × 11	–	–	4.5 × 10	4.5 × 10	6 × 10	8 × 11
	–	–	–	–	–	–	6.5 × 18
15	–	–	–	–	4.5 × 10	6 × 10	–
22	–	–	–	4.5 × 10	6 × 10	8 × 11	8 × 18
	–	–	–	–	–	6.5 × 18	–
33	–	–	4.5 × 10	–	6 × 10	–	10 × 18
47	–	4.5 × 10	–	6 × 10	8 × 11	8 × 18	10 × 25
	–	–	–	–	6.5 × 18	–	–
68	4.5 × 10	–	6 × 10	–	–	10 × 18	–
100	–	6 × 10	–	8 × 11	8 × 18	10 × 25	–
	–	–	–	6.5 × 18	–	–	–
150	6 × 10	–	8 × 11	8 × 18	10 × 18	–	–
	–	–	6.5 × 18	–	–	–	–
220	–	8 × 11	8 × 18	10 × 18	10 × 25	–	–
	–	6.5 × 18	–	–	–	–	–
330	–	8 × 18	10 × 18	10 × 25	–	–	–
470	8 × 18	10 × 18	10 × 25	–	–	–	–
680	10 × 18	10 × 25	–	–	–	–	–
1000⁽¹⁾	10 × 25	–	–	–	–	–	–

Note

- For larger CV-values see data sheet "021 ASM".

Aluminium electrolytic capacitors
Axial Standard

030/031 AS

MECHANICAL DATA, AVAILABLE FORMS AND PACKAGING QUANTITIES

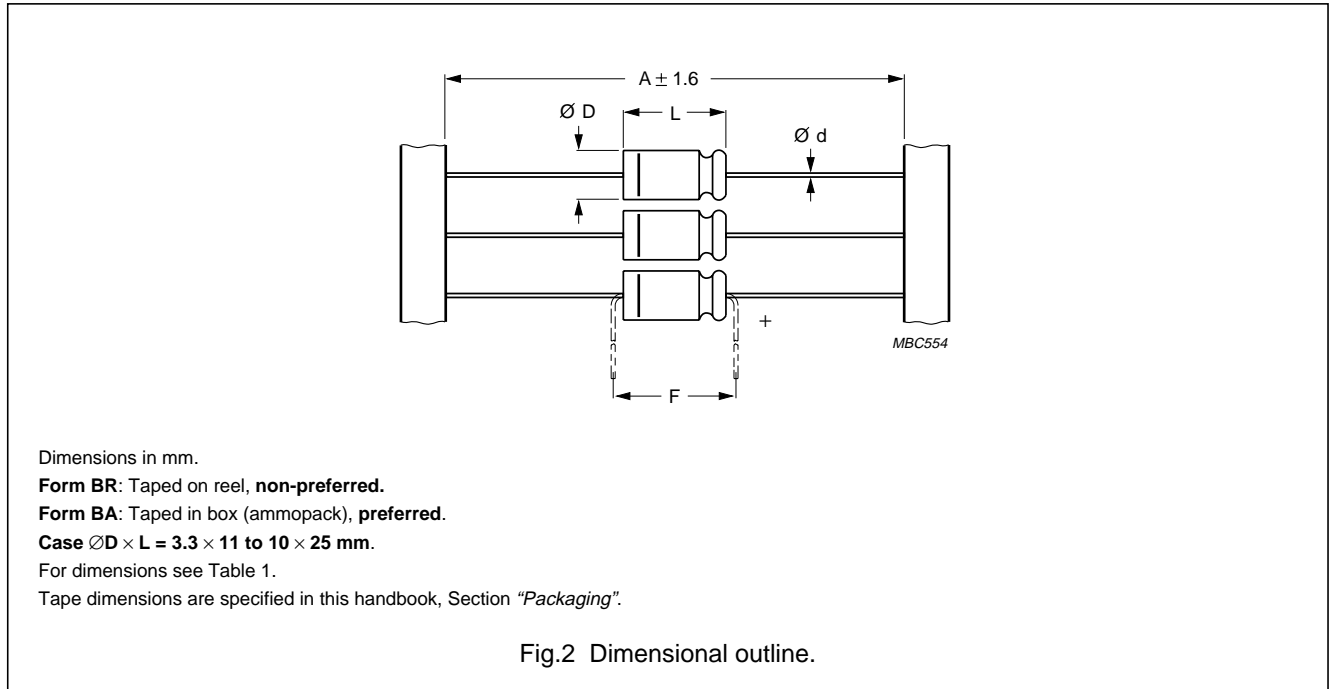

Table 1 Axial; Physical dimensions, mass and packaging quantities; see Fig. 2

NOMINAL CASE SIZE $\varnothing D \times L$ (mm)	CASE CODE	AXIAL FORM BA and BR					MASS (g)	PACKAGING QUANTITIES	
		$\varnothing d$ (mm)	A (mm)	$\varnothing D_{max}$ (mm)	L_{max} (mm)	F_{min} (mm)		FORM BA	FORM BR
3.3 × 11	1	0.6	63.5 ± 1.5	3.5	12	17.5	≈ 0.35	1000	4000
4.5 × 10	2	0.6	63.5 ± 1.5	5.0	10.5	15	≈ 0.5	1000	3000
6 × 10	3	0.6	63.5 ± 1.5	6.3	10.5	15	≈ 0.7	1000	1000
8 × 11	5a	0.6	63.5 ± 1.5	8.5	11.5	15	≈ 1.1	500	500
6.5 × 18	4	0.8	73 ± 1.6	6.9	18.5	25	≈ 1.3	1000	1000
8 × 18	5	0.8	73 ± 1.6	8.5	18.5	25	≈ 1.7	500	500
10 × 18	6	0.8	73 ± 1.6	10.5	18.5	25	≈ 2.5	500	500
10 × 25	7	0.8	73 ± 1.6	10.5	25.0	30	≈ 3.3	500	500

Aluminium electrolytic capacitors Axial Standard

030/031 AS

Ordering example

Electrolytic capacitor 031 series.

330 $\mu\text{F}/10\text{ V}$; $-10/+50\%$.

Nominal case size: $\varnothing 8 \times 18\text{ mm}$; Form BA.

Catalogue number: 2222 031 34331.

ELECTRICAL DATA AND ORDERING INFORMATION

Unless otherwise specified, all electrical values in Table 2 apply at $T_{\text{amb}} = 20\text{ }^{\circ}\text{C}$,
 $P = 86\text{ to }106\text{ kPa}$, $\text{RH} = 45\text{ to }75\%$.

SYMBOL	DESCRIPTION
C_R	rated capacitance at 100 Hz, tolerance $-10\text{ to }+50\%$
I_R	rated RMS ripple current at 100 Hz, $85\text{ }^{\circ}\text{C}$
I_{L1}	max. leakage current after 1 minute at U_R
I_{L5}	max. leakage current after 5 minutes at U_R
$\text{Tan } \delta$	max. dissipation factor at 100 Hz
ESR	equivalent series resistance at 100 Hz (calculated from $\text{tan } \delta_{\text{max}}$ and C_R)
Z	max. impedance at 10 kHz

Table 2 Electrical data and ordering information; preferred types in **bold**

U_R (V)	C_R 100 Hz (μF)	NOMINAL CASE SIZE $\varnothing D \times L$ (mm)	CASE CODE	I_R 100 Hz $85\text{ }^{\circ}\text{C}$ (mA)	I_{L1} 1 min (μA)	I_{L5} 5 min (μA)	$\text{Tan } \delta$ 100 Hz	ESR 100 Hz (Ω)	Z 10 kHz (Ω)	CATALOGUE NUMBER 2222	
										TAPED ON REEL FORM BR	TAPED IN BOX FORM BA
6.3	10	3.3×11	1	15	5	5	0.30	47.8	20	030 23109	030 33109
	68	4.5×10	2	75	22	5.9	0.25	5.86	2.9	030 23689	030 33689
	150	6×10	3	120	10	6.9	0.25	2.66	1.3	030 23151	030 33151
	470	8×18	5	330	22	11	0.25	0.85	0.43	031 23471	031 33471
	680	10×18	6	430	30	14	0.25	0.59	0.29	031 23681	031 33681
	1000	10×25	7	560	42	18	0.25	0.40	0.20	031 23102	031 33102
10	47	4.5×10	2	70	24	5.9	0.20	6.78	3.4	030 24479	030 34479
	100	6×10	3	10	110	7	0.20	3.19	1.6	030 24101	030 34101
	220	8×11	5a	210	18	9.4	0.20	1.45	0.73	030 24221	030 34221
	220	6.5×18	4	210	18	9.4	0.20	1.45	0.73	031 24221	031 34221
	330	8×18	5	310	24	12	0.20	0.97	0.48	031 24331	031 34331
	470	10×18	6	410	33	14	0.20	0.68	0.34	031 24471	031 34471
	680	10×25	7	510	45	19	0.20	0.47	0.24	031 24681	031 34681

Aluminium electrolytic capacitors
Axial Standard

030/031 AS

U _R (V)	C _R 100 Hz (μF)	NOMINAL CASE SIZE ∅D × L (mm)	CASE CODE	I _R 100 Hz 85 °C (mA)	I _{L1} 1 min (μA)	I _{L5} 5 min (μA)	Tan δ 100 Hz	ESR 100 Hz (Ω)	Z 10 kHz (Ω)	CATALOGUE NUMBER 2222	
										TAPED ON REEL FORM BR	TAPED IN BOX FORM BA
16	4.7	3.3 × 11	1	15	5	5	0.20	67.8	26	030 25478	030 35478
	33	4.5 × 10	2	65	27	6.1	0.16	7.72	3.6	030 25339	030 35339
	68	6 × 10	3	110	11	7.2	0.16	3.75	1.8	030 25689	030 35689
	150	8 × 11	5a	200	19	9.8	0.16	1.70	0.80	030 25151	030 35151
	150	6.5 × 18	4	200	19	9.8	0.16	1.70	0.80	031 25151	031 35151
	220	8 × 18	5	270	26	12	0.16	1.16	0.55	031 25221	031 35221
	330	10 × 18	6	410	36	16	0.16	0.78	0.36	031 25331	031 35331
	470	10 × 25	7	480	49	20	0.16	0.55	0.26	031 25471	031 35471
25	10	4.5 × 10	2	50	13	5.5	0.14	22.3	9	030 26109	030 36109
	22	4.5 × 10	2	60	28	6.1	0.14	10.2	4.1	030 26229	030 36229
	47	6 × 10	3	100	12	7.4	0.14	4.8	1.9	030 26479	030 36479
	100	8 × 11	5a	160	19	10	0.14	2.23	0.90	030 26101	030 36101
	100	6.5 × 18	4	160	19	10	0.14	2.23	0.90	031 26101	031 36101
	150	8 × 18	5	240	27	13	0.14	1.49	0.60	031 26151	031 36151
	220	10 × 18	6	350	37	16	0.14	1.02	0.41	031 26221	031 36221
	330	10 × 25	7	460	54	22	0.14	0.68	0.27	031 26331	031 36331
40	2.2	3.3 × 11	1	15	5	5	0.15	109	32	030 27228	030 37228
	10	4.5 × 10	2	50	20	5.8	0.11	17.6	7	030 27109	030 37109
	15	4.5 × 10	2	55	30	6.2	0.11	11.7	4.7	030 27159	030 37159
	22	6 × 10	3	75	9	6.8	0.11	8.0	3.2	030 27229	030 37229
	33	6 × 10	3	95	12	7.7	0.11	5.31	2.1	030 27339	030 37339
	47	8 × 11	5a	150	16	8.8	0.11	3.73	1.5	030 27479	030 37479
	47	6.5 × 18	4	150	16	8.8	0.11	3.73	1.5	031 27479	031 37479
	100	8 × 18	5	220	28	13	0.11	1.75	0.70	031 27101	031 37101
	150	10 × 18	6	300	40	17	0.11	1.17	0.47	031 27151	031 37151
	220	10 × 25	7	430	57	23	0.11	0.80	0.32	031 27221	031 37221

Aluminium electrolytic capacitors
Axial Standard

030/031 AS

U _R (V)	C _R 100 Hz (μF)	NOMINAL CASE SIZE ∅D × L (mm)	CASE CODE	I _R 100 Hz 85 °C (mA)	I _{L1} 1 min (μA)	I _{L5} 5 min (μA)	Tan δ 100 Hz	ESR 100 Hz (Ω)	Z 10 kHz (Ω)	CATALOGUE NUMBER 2222	
										TAPED ON REEL FORM BR	TAPED IN BOX FORM BA
63	1.0	3.3 × 11	1	10	5	5	0.12	191	55	030 90067	030 90068
	1.0	4.5 × 10	2	13	5	5	0.09	143	55	030 28108	030 38108
	2.2	4.5 × 10	2	25	7	5.3	0.09	65.2	25	030 28228	030 38228
	3.3	4.5 × 10	2	35	11	5.4	0.09	46.5	17	030 28338	030 38338
	4.7	4.5 × 10	2	40	15	5.6	0.09	30.5	12	030 28478	030 38478
	6.8	4.5 × 10	2	46	22	5.9	0.09	21.1	8.1	030 28688	030 38688
	10	6 × 10	3	70	7	6.3	0.08	12.8	5.5	030 28109	030 38109
	15	6 × 10	3	79	10	6.9	0.08	8.5	3.7	030 28159	030 38159
	22	8 × 11	5a	110	13	7.8	0.08	5.79	2.5	030 28229	030 38229
	22	6.5 × 18	4	110	13	7.8	0.08	5.79	2.5	031 28229	031 38229
	47	8 × 18	5	190	22	11	0.08	2.71	1.2	031 28479	031 38479
	68	10 × 18	6	250	30	14	0.08	1.88	0.81	031 28689	031 38689
100	10 × 25	7	300	42	18	0.08	1.28	0.55	031 28101	031 38101	
100	0.47	4.5 × 10	2	9	5	5	0.08	271	96	030 29477	030 39477
	1.0	4.5 × 10	2	20	5	5	0.08	128	45	030 29108	030 39108
	2.2	4.5 × 10	2	30	11	11	0.08	57.9	21	030 29228	030 39228
	3.3	4.5 × 10	2	40	17	17	0.08	38.6	14	030 29338	030 39338
	4.7	6 × 10	3	50	22	22	0.07	23.7	9.6	030 29478	030 39478
	6.8	6 × 10	3	70	34	34	0.07	16.4	6.6	030 29688	030 39688
	10	8 × 11	5a	90	50	50	0.07	11.2	4.5	030 29109	030 39109
	10	6.5 × 18	4	90	50	50	0.07	11.2	4.5	031 29109	031 39109
	22	8 × 18	5	120	80	80	0.07	5.07	2.1	031 29229	031 39229
	33	10 × 18	6	200	119	119	0.07	3.38	1.4	031 29339	031 39339
	47	10 × 25	7	260	33	33	0.07	2.37	0.96	031 29479	031 39479

Aluminium electrolytic capacitors

Axial Standard

030/031 AS

Additional electrical data

PARAMETER	CONDITIONS	VALUE
Voltage		
Surge voltage for short periods		$U_s \leq 1.15 \times U_R$
Reverse voltage		$U_{rev} \leq 1 \text{ V}$
Current		
Leakage current	after 1 minute at U_R : case $\varnothing D \times L = 3.3 \times 11$ and 4.5×10 mm case $\varnothing D \times L = 6 \times 10$ to 10×25 mm	$I_{L1} \leq 0.05C_R \times U_R$ or $5 \mu\text{A}$, whichever is greater I_{L1} for $CV \leq 1000 \mu\text{C}$: $\leq 0.01C_R \times U_R$ or $1 \mu\text{A}$, whichever is greater I_{L1} for $CV > 1000 \mu\text{C}$: $\leq 0.006C_R \times U_R + 4 \mu\text{A}$
	after 5 minutes: $U_R = 6.3$ to 63 V $U_R = 100 \text{ V}$	$I_{L5} \leq 0.002C_R \times U_R + 5 \mu\text{A}$ $I_{L5} \leq 0.006C_R \times U_R + 4 \mu\text{A}$
Inductance		
Equivalent series inductance (ESL)	case $\varnothing D \times L$ mm: 3.3×11 4.5×10 6×10 8×11 6.5×18 8×18 10×18 10×25	typ. 11 nH typ. 10 nH typ. 22 nH typ. 85 nH typ. 25 nH typ. 40 nH typ. 61 nH typ. 38 nH

MARKING

The capacitors are marked (where possible) with the following information:

- Rated capacitance (in μF)
- Tolerance on rated capacitance, code letter in accordance with "IEC 62" (not for case code 1)
- Rated voltage (in V)
- Group number (030 or 031)
- Code indicating factory of origin
- Name of manufacturer (PHILIPS)
- Date code, in accordance with "IEC 62"
- Band to identify the negative terminal
- '+' sign to indicate the positive terminal (not for case sizes $L < 18$ mm).

Aluminium electrolytic capacitors
Axial Standard

030/031 AS

Capacitance (C)

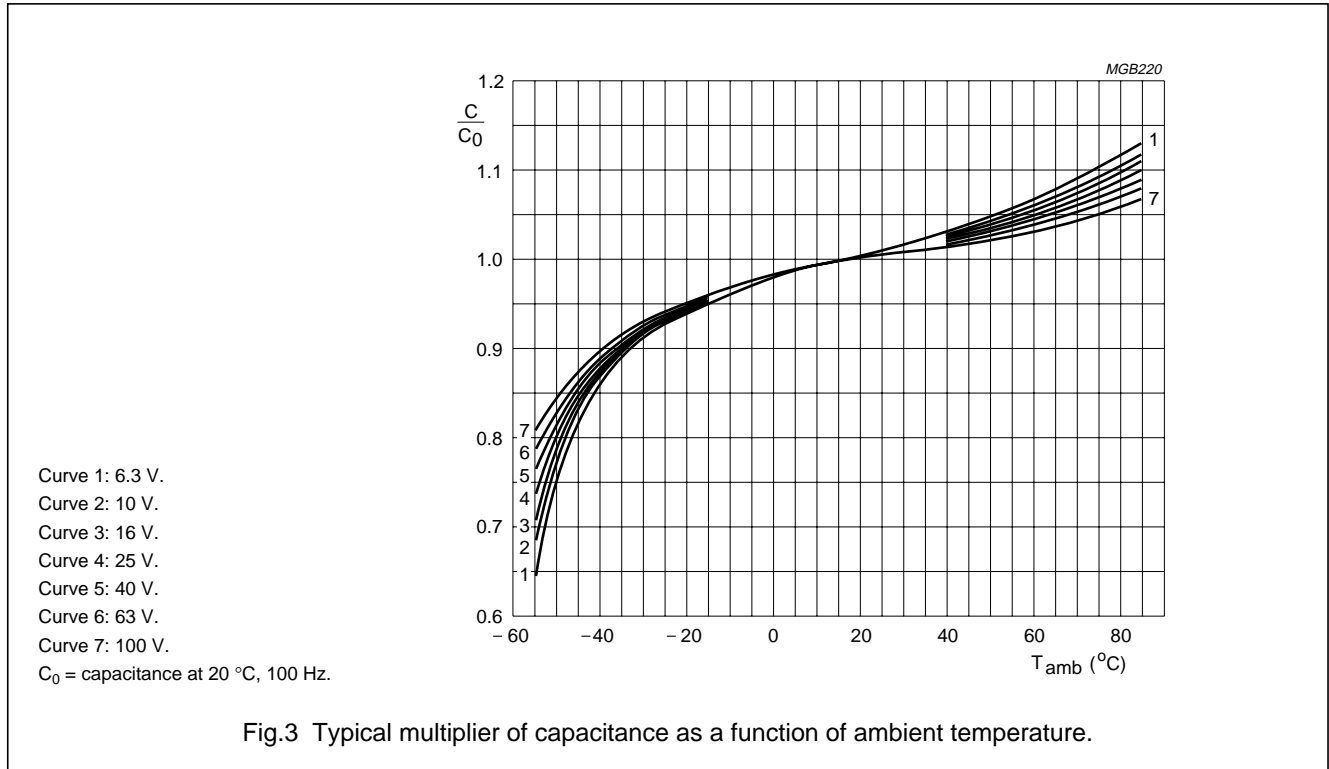

Fig.3 Typical multiplier of capacitance as a function of ambient temperature.

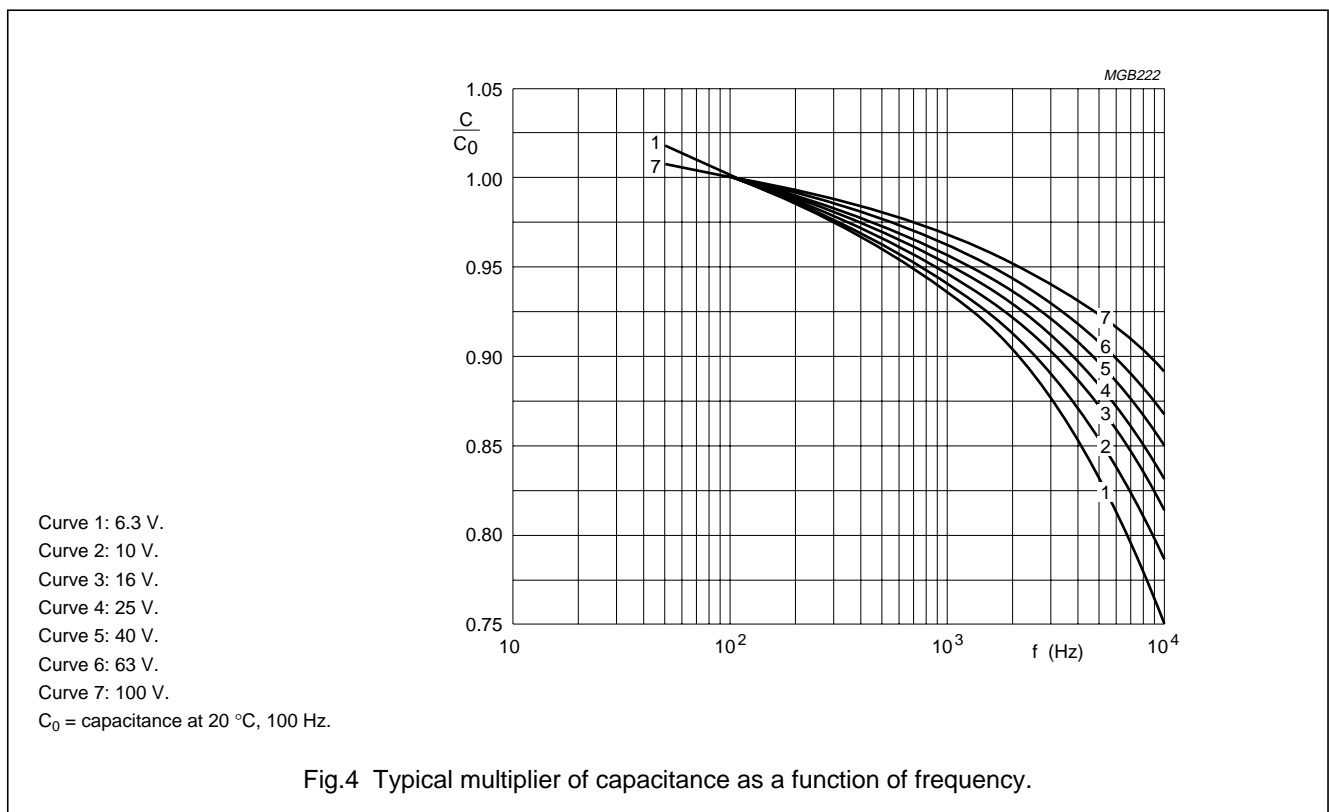

Fig.4 Typical multiplier of capacitance as a function of frequency.

A

Aluminium electrolytic capacitors
Axial Standard

030/031 AS

Equivalent series resistance (ESR)

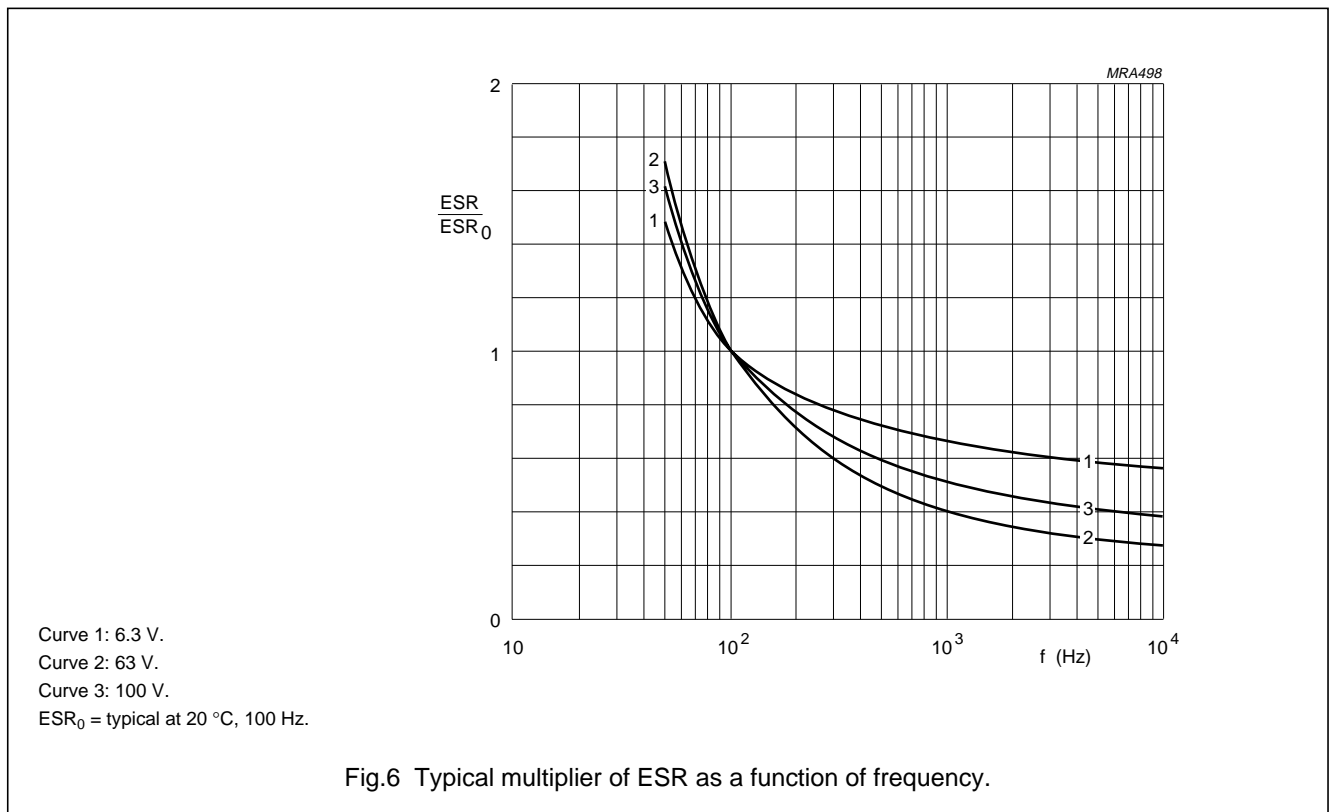
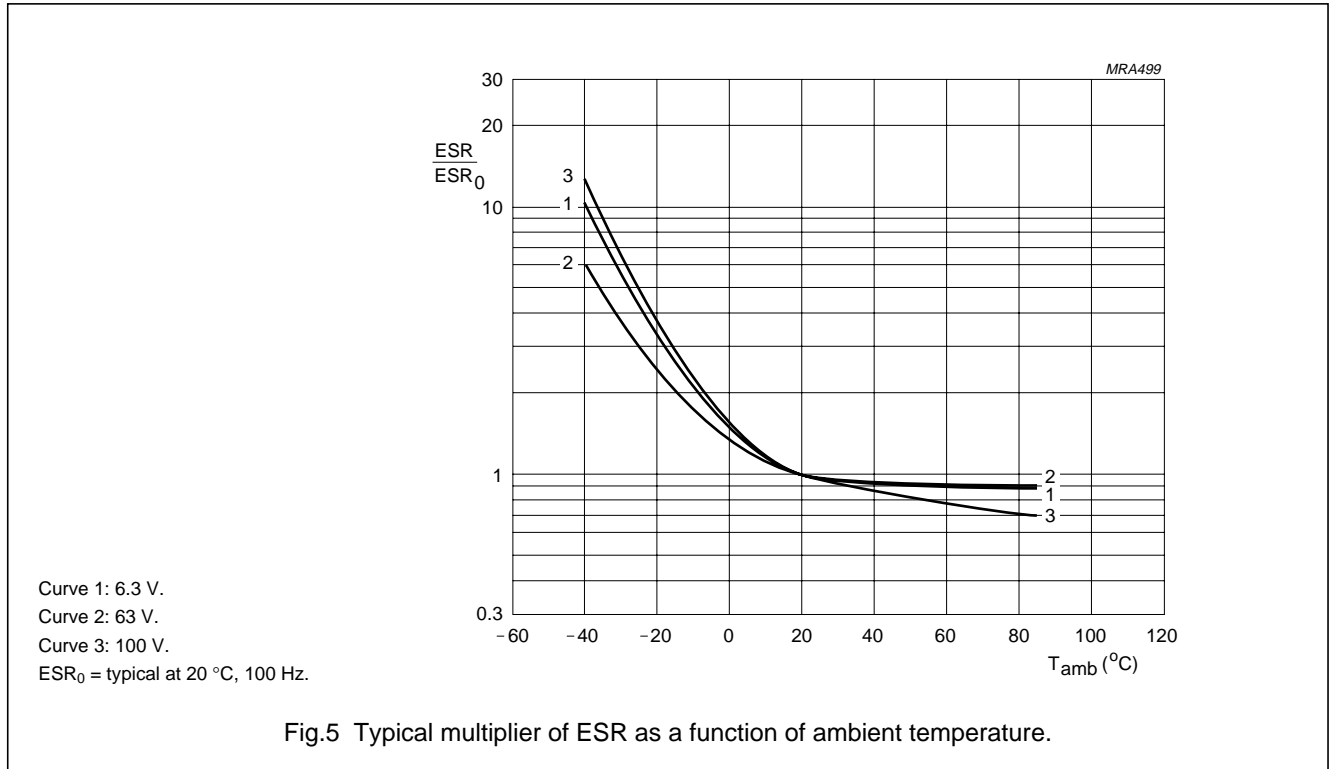

Aluminium electrolytic capacitors
Axial Standard

030/031 AS

Impedance (Z)

Table 3 Impedance × capacitance values at 10 kHz

T _{amb}	Z × C _R (Ω × μF) at 10 kHz						
	6.3 V	10 V	16 V	25 V	40 V	63 V	100 V
+20 °C	≤200	≤160	≤120	≤90	≤70	≤55	≤45
-25 °C	≤1200	≤750	≤560	≤400	≤300	≤180	≤130
-40 °C	≤3200	≤2000	≤1500	≤1100	≤900	≤500	≤350

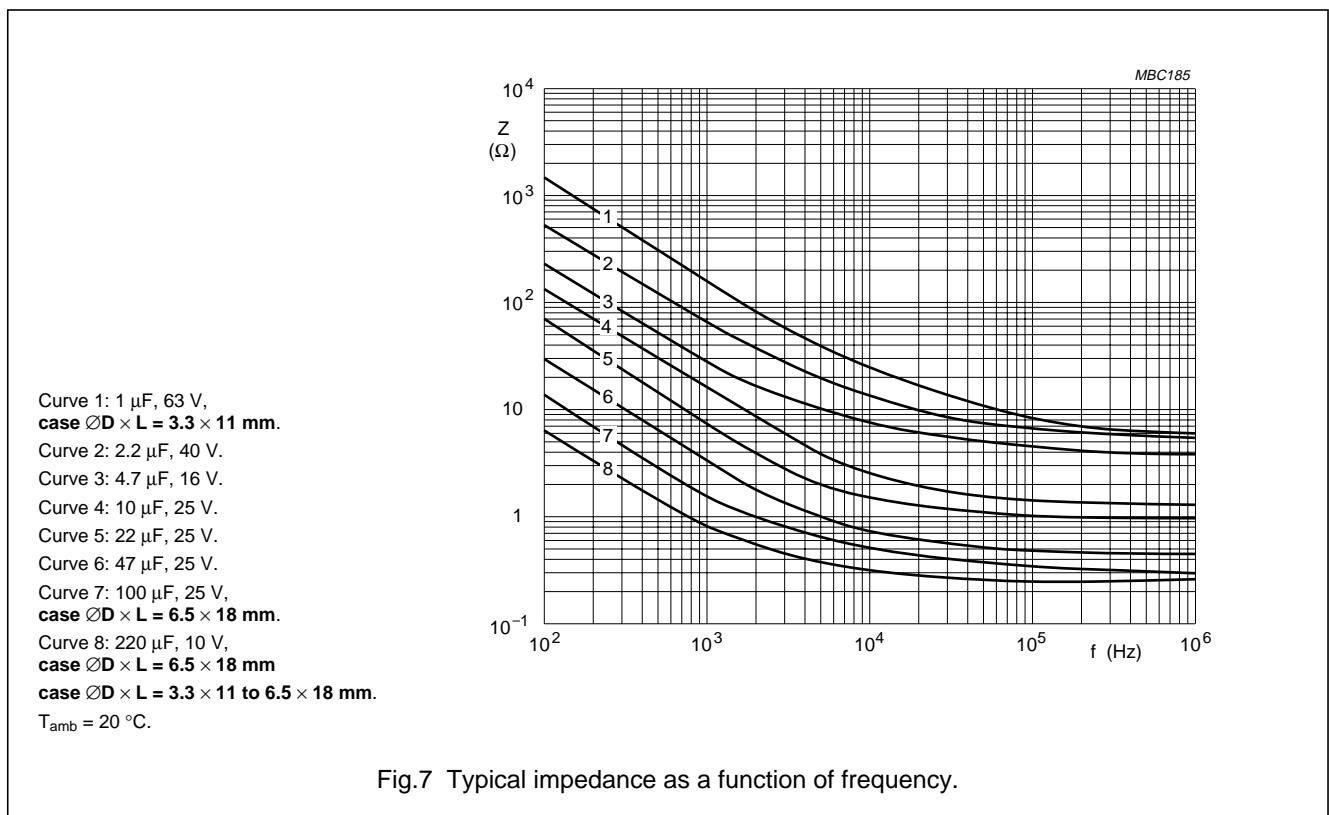

A

Aluminium electrolytic capacitors
Axial Standard

030/031 AS

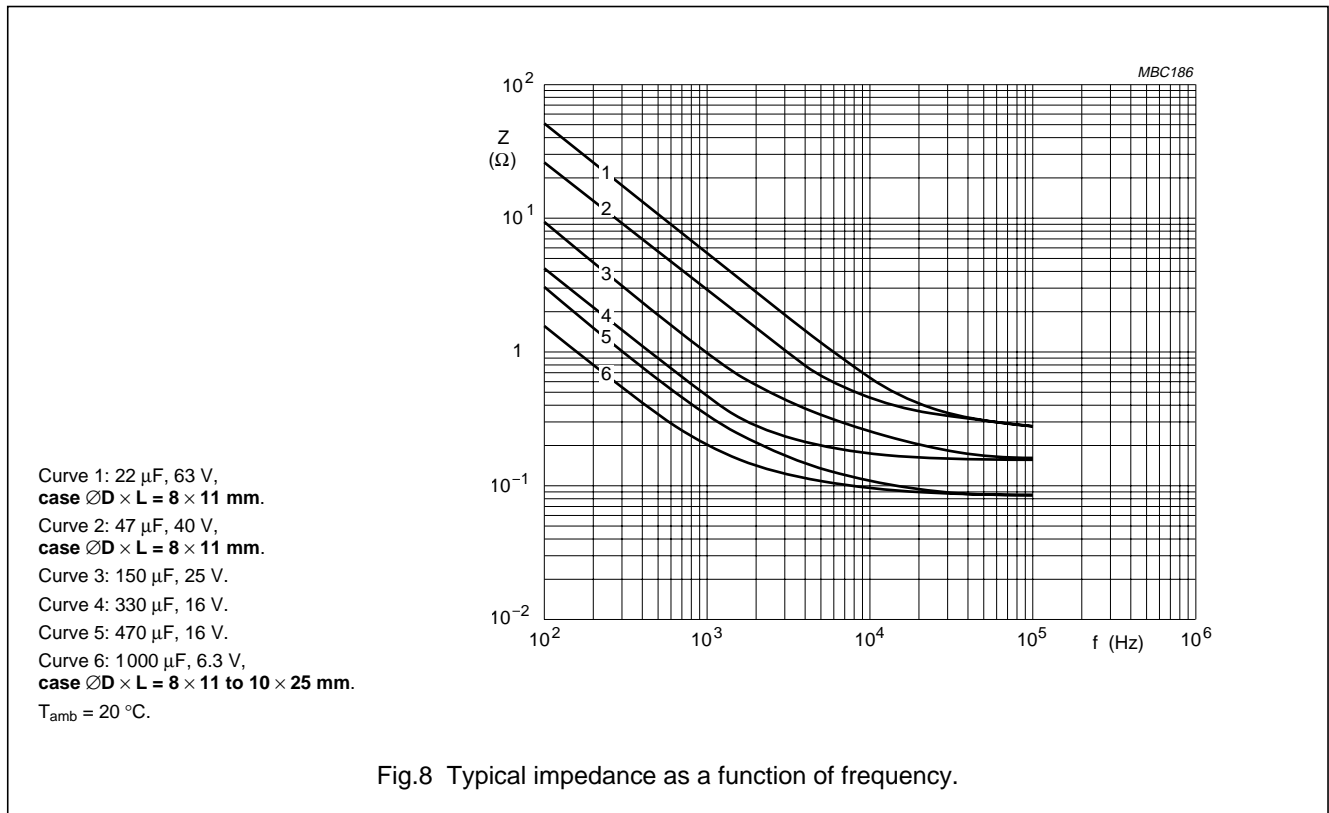

Aluminium electrolytic capacitors
Axial Standard

030/031 AS

RIPPLE CURRENT AND USEFUL LIFE

Table 4 Multiplier of ripple current (I_R/I_{R0}) as a function of frequency; I_{R0} = ripple current at 85 °C, 100 Hz

FREQUENCY (Hz)	I_R MULTIPLIER		
	$U_R = 6.3$ to 10 V	$U_R = 16$ to 25 V	$U_R = 40$ to 100 V
50	0.95	0.9	0.85
100	1.0	1.0	1.0
300	1.07	1.12	1.2
1000	1.12	1.2	1.3
3000	1.15	1.25	1.35
≥ 10000	1.2	1.3	1.4

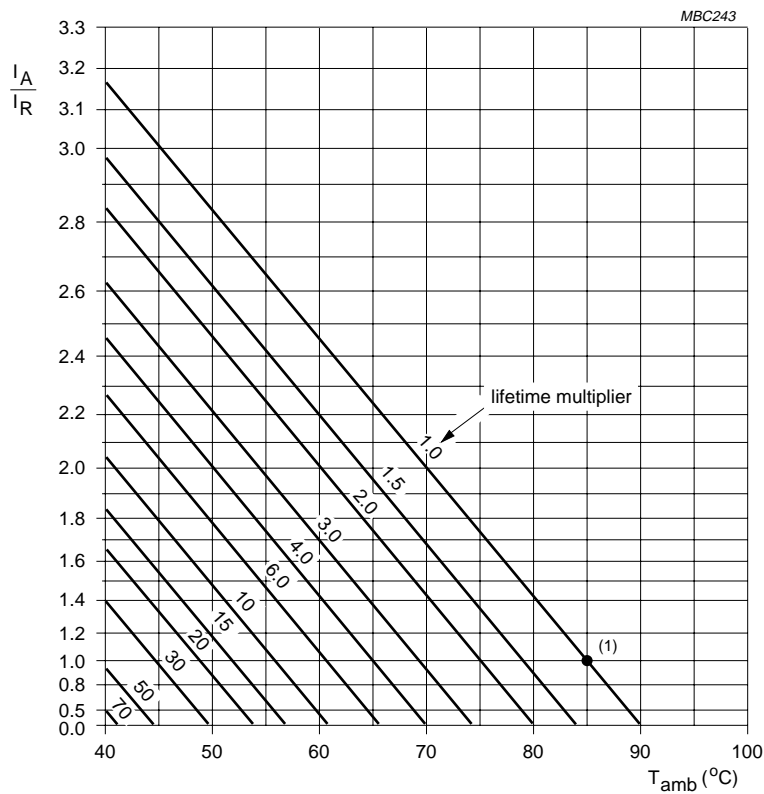

I_A = actual ripple current at 100 Hz.

I_R = rated ripple current at 100 Hz, 85 °C.

(1) Useful life at 85 °C and I_R applied:

case $\varnothing D \times L = 3.3 \times 11$ mm: 1500 hours

case $\varnothing D \times L = 4.5 \times 10$ to 10×25 mm: 3000 hours.

Fig.9 Multiplier of useful life as a function of ambient temperature and ripple current load.

A

Aluminium electrolytic capacitors

Axial Standard

030/031 AS

SPECIFIC TESTS AND REQUIREMENTS

General tests and requirements are specified in this handbook, Section "Tests and Requirements".

Table 5 Test procedures and requirements

TEST		PROCEDURE (quick reference)	REQUIREMENTS
NAME OF TEST	REFERENCE		
Case $\varnothing D \times L = 3.3 \times 11$ mm			
Endurance	IEC 384-4/ CECC 30300 subclause 4.13	$T_{amb} = 85$ °C; U_R applied; 1000 hours	$\Delta C/C: \pm 20\%$ $\tan \delta \leq 2 \times$ spec. limit $Z \leq 3 \times$ spec. limit $I_{L5} \leq$ spec. limit
Useful life	CECC 30301 subclause 1.8.1	$T_{amb} = 85$ °C; U_R and I_R applied; 1500 hours	$\Delta C/C: \pm 50\%$ $\tan \delta \leq 3 \times$ spec. limit $Z \leq 3 \times$ spec. limit $I_{L5} \leq$ spec. limit no short or open circuit total failure percentage: $\leq 3\%$
Shelf life (storage at high temperature)	IEC 384-4/ CECC 30300 subclause 4.17	$T_{amb} = 85$ °C; no voltage applied; 500 hours after test: U_R to be applied for 30 minutes, 24 to 48 hours before measurement	$\Delta C/C, \tan \delta, Z:$ for requirements see 'Endurance test' above $I_{L5} \leq 2 \times$ spec. limit
Case $\varnothing D \times L = 4.5 \times 10$ to 10×25 mm			
Endurance	IEC 384-4/ CECC 30300 subclause 4.13	$T_{amb} = 85$ °C; U_R applied; 2000 hours	$U_R \leq 6.3$ V; $\Delta C/C: +15/-30\%$ $U_R > 6.3$ V; $\Delta C/C: \pm 15\%$ $\tan \delta \leq 1.3 \times$ spec. limit $Z \leq 2 \times$ spec. limit $I_{L5} \leq$ spec. limit
Useful life	CECC 30301 subclause 1.8.1	$T_{amb} = 85$ °C; U_R and I_R applied; 3000 hours	$U_R \leq 6.3$ V; $\Delta C/C: +45/-50\%$ $U_R > 6.3$ V; $\Delta C/C: \pm 45\%$ $\tan \delta \leq 3 \times$ spec. limit $Z \leq 3 \times$ spec. limit $I_{L5} \leq$ spec. limit no short or open circuit total failure percentage: $\leq 1\%$
Shelf life (storage at high temperature)	IEC 384-4/ CECC 30300 subclause 4.17	$T_{amb} = 85$ °C; no voltage applied; 500 hours after test: U_R to be applied for 30 minutes, 24 to 48 hours before measurement	$\Delta C/C, \tan \delta, Z:$ for requirements see 'Endurance test' above $I_{L5} \leq 2 \times$ spec. limit