

DATA SHEET

TDA2614 6 W hi-fi audio power amplifier

Product specification
File under Integrated Circuits, IC01

July 1994

6 W hi-fi audio power amplifier**TDA2614****FEATURES**

- Requires very few external components
- No switch-on/switch-off clicks
- Input mute during switch-on and switch-off
- Low offset voltage between output and ground
- Hi-fi in accordance with IEC 268 and DIN 45500
- Short-circuit proof and thermal protected
- Mute possibility.

GENERAL DESCRIPTION

The TDA2614 is a power amplifier in a 9-lead single-in-line (SIL9) plastic medium power package. It has been especially designed for mains fed applications, such as TV and radio.

QUICK REFERENCE DATA

SYMBOL	PARAMETER	CONDITIONS	MIN.	TYP.	MAX.	UNIT
V_P	positive supply voltage range		15	–	42	V
P_O	output power	$V_S = 24\text{ V}$; THD = 0.5%	–	6.5	–	W
G_v	internal voltage gain		–	30	–	dB
SVRR	supply voltage ripple rejection		–	45	–	dB
V_{no}	noise output voltage		–	70	–	μV

ORDERING INFORMATION

EXTENDED TYPE NUMBER	PACKAGE			
	PINS	PIN POSITION	MATERIAL	CODE
TDA2614	9	SIL	plastic	SOT110 ⁽¹⁾

Note

1. SOT110-1; 1996 August 21.

6 W hi-fi audio power amplifier

TDA2614

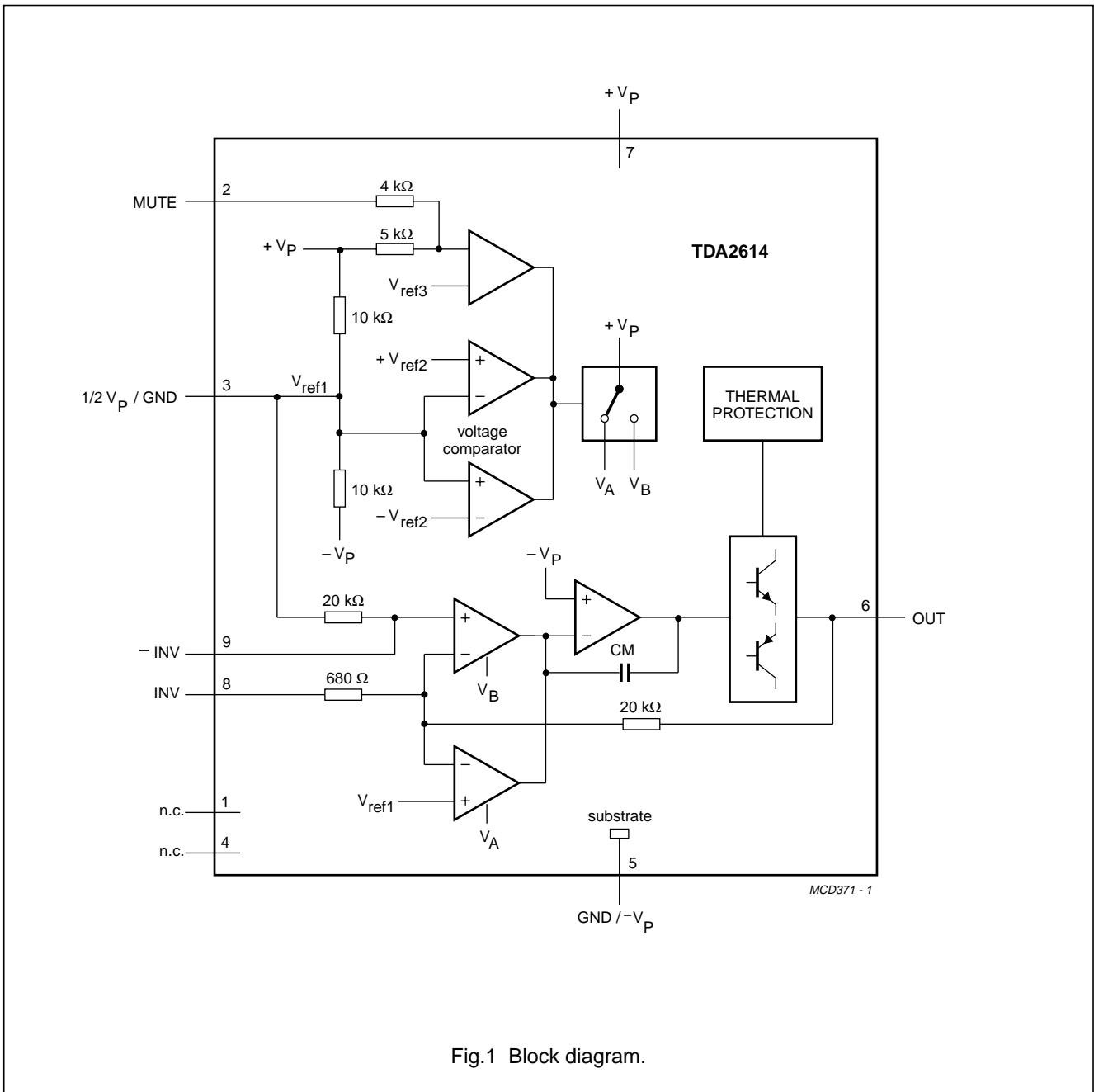

Fig.1 Block diagram.

6 W hi-fi audio power amplifier

TDA2614

PINNING

SYMBOL	PIN	DESCRIPTION
n.c.	1	not connected
MUTE	2	mute input
1/2V _P /GND	3	1/2 supply (or ground at symmetrical power supplies)
n.c.	4	not connected
GND/-V _P	5	ground (or negative supply rail at symmetrical power supplies)
OUT	6	output
V _P	7	supply voltage
INV	8	inverting input
-INV	9	non-inverting input

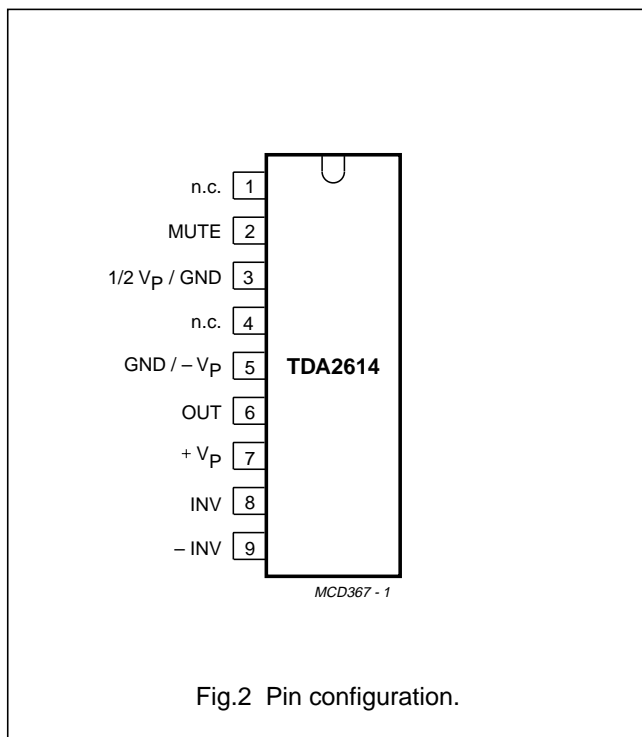

FUNCTIONAL DESCRIPTION

The TDA2614 is a hi-fi power amplifier designed for mains fed applications, such as radio and TV. The circuit is optimally designed for asymmetrical power supplies, but is also well-suited to symmetrical power supply systems.

An output power of 6 W (THD = 0.5%) can be delivered into an 8 Ω load with a supply of 24 V. The gain is internally fixed at 30 dB, thus offering a low gain spread.

A special feature is the input mute circuit. This circuit disconnects the non-inverting input when the supply voltage drops below 10 V, while the amplifier still retains its DC operating adjustment. The circuit features suppression of unwanted signals at the input, during switch-on and switch-off.

The mute circuit can also be activated via pin 2. When a current at 300 μA is present at pin 2, the circuit is in the mute condition.

The device is provided with two thermal protection circuits. One circuit measures the average temperature of the crystal and the other measure the momentary temperature of the power transistors. These control circuits attack at temperatures in excess of 150 °C, so a crystal operating temperature of max. 150 °C can be used without extra distortion.

With the derating value of 8 K/W, the heatsink can be calculated as follows:

at $R_L = 8 \Omega$ and $V_S = 24 V$, dissipation is 4.1 W.

With a maximum ambient temperature of 60 °C, the thermal resistance of the heatsink is:

$$R_{th} = \frac{150 - 60}{4.1} - 8 = 14 \text{ K/W.}$$

6 W hi-fi audio power amplifier

TDA2614

LIMITING VALUES

In accordance with the Absolute maximum System (IEC 134).

SYMBOL	PARAMETER	CONDITIONS	MIN.	MAX.	UNIT
V_P	positive supply voltage		–	42	V
I_{OSM}	non-repetitive peak output current		–	4	A
P_{tot}	total power dissipation	see Fig.3	–	15	W
T_{stg}	storage temperature range		–55	+150	°C
T_{XTAL}	crystal temperature		–	+150	°C
T_{amb}	ambient operating temperature range		–25	+150	°C
t_{sc}	short circuit time	short circuit to ground; note 1	–	1	h

Note to the limiting values

- For asymmetrical power supplies (with the load short-circuited), the maximum unloaded supply voltage is limited to $V_P = 28\text{ V}$, and with an internal supply resistance of $R_S \geq 4\ \Omega$, the maximum unloaded supply voltage is limited to 32 V (**with the load short-circuited**). For symmetrical power supplies, the circuit is short-circuit-proof up to $V_P = \pm 21\text{ V}$.

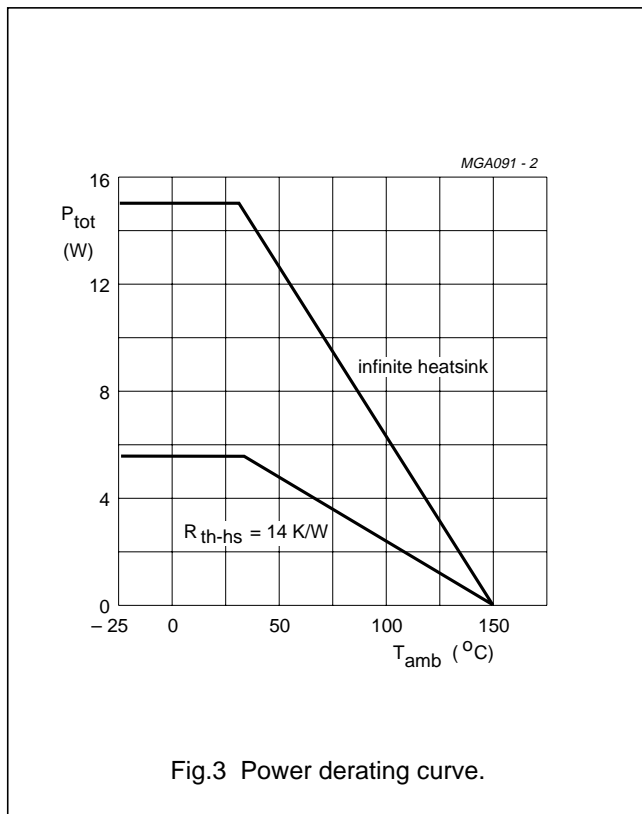

Fig.3 Power derating curve.

THERMAL RESISTANCE

SYMBOL	PARAMETER	THERMAL RESISTANCE
$R_{th\ j-c}$	from junction to case	8 K/W

6 W hi-fi audio power amplifier

TDA2614

CHARACTERISTICS

SYMBOL	PARAMETER	CONDITIONS	MIN.	TYP.	MAX.	UNIT
Supply						
V_P	supply voltage range		–	24	42	V
I_{ORM}	repetitive peak output current		–	2.2	–	A
Operating position; note 1						
V_P	supply voltage range		15	24	42	V
I_P	total quiescent current		10	20	35	mA
P_O	output power	THD = 0.5% THD = 10% THD = 0.5%; $R_L = 4 \Omega$ THD = 10%; $R_L = 4 \Omega$	5 6.5 – –	6.5 8.5 10 14	– – – –	W W W W
THD	total harmonic distortion	$P_O = 4 \text{ W}$	–	0.15	0.2	%
B	power bandwidth	THD = 0.5%; note 2	–	30 to 20 000	–	Hz
G_V	voltage gain		29	30	31	dB
$ \Delta V_{3-6} $	DC output offset voltage		–	30	200	mV
V_{no}	noise output voltage	note 3	–	70	140	μV
$ Z_i $	input impedance		14	20	26	$k\Omega$
SVRR	supply voltage ripple rejection	note 4	35	45	–	dB
I_{bias}	input bias current		–	0.3	–	μA
MUTE POSITION (AT $I_{MUTE} \geq 300 \mu\text{A}$)						
V_O	output voltage	$V_I = 600 \text{ mV}$	–	0.1	1.0	mV
Z_{2-7}	mute input impedance		–	9	–	$k\Omega$
I_P	total quiescent current		10	20	35	mA
V_{no}	noise output voltage	note 3	–	70	140	μV
SVRR	supply voltage ripple rejection	note 4	35	44	–	dB
$ \Delta V_{3-6} $	DC output offset voltage		–	40	200	mV
$ \Delta V_{off} $	offset voltage with respect to operating position		–	4	150	mV
I_2	current if pin 2 is connected to pin 5		–	–	6	mA
Mute position; note 5						
V_P	positive supply voltage range		4	–	10	V
I_P	total quiescent current	$R_L = \infty$	5	15	20	mA
V_O	output voltage	$V_I = 600 \text{ mV}$	–	0.1	1.0	mV
V_{no}	noise output voltage	note 3	–	70	140	μV
SVRR	supply voltage ripple rejection	note 4	35	44	–	dB
$ \Delta V_{3-6} $	DC output offset voltage		–	40	200	mV

6 W hi-fi audio power amplifier

TDA2614

SYMBOL	PARAMETER	CONDITIONS	MIN.	TYP.	MAX.	UNIT
Operating position; note 6						
$\pm V_P$	supply voltage range		7.5	12	21	V
I_P	total quiescent current		10	20	35	mA
P_O	output power	THD = 0.5%	5	6.5	–	W
		THD = 10%	6.5	8	–	W
THD	total harmonic distortion	$P_O = 4$ W	–	0.13	0.2	%
B	power bandwidth	THD = 0.5%; note 2	–	40 to 20000	–	Hz
G_v	voltage gain		29	30	31	dB
V_{no}	noise output voltage	note 3	–	70	140	μ V
$ Z_i $	input impedance		14	20	26	k Ω
SVRR	supply voltage ripple rejection		40	55	–	dB
I_{bias}	input bias current		–	0.3	–	μ A
$ V_{GND} $	DC output offset voltage		–	30	200	mV
MUTE POSITION (AT $I_{MUTE} \geq 300 \mu A$)						
V_O	output voltage	$V_I = 600$ mV	–	0.1	1.0	mV
Z_{2-7}	mute input impedance	note 7	6.7	9	11.3	k Ω
I_P	total quiescent current	$R_L = \infty$	10	20	35	mA
V_{no}	noise output voltage	note 3	–	70	140	μ V
SVRR	supply voltage ripple rejection	note 4	40	55	–	dB
$ \Delta V_{GND} $	DC output offset voltage		–	40	200	mV
$ \Delta V_{off} $	offset voltage with respect to operating position		–	4	150	mV
I_2	current if pin 2 is connected to pin 5		–	–	6	mA

Notes to the characteristics

- $V_P = 24$ V; $R_L = 8 \Omega$; $T_{amb} = 25$ °C; $f = 1$ kHz; asymmetrical power supply $I_{MUTE} < 30 \mu A$. See Fig.5
- The power bandwidth is measured at an output power of $P_{O\ max} - 3$ dB.
- The noise output voltage (RMS value) is measured at $R_S = 2$ k Ω , unweighted (20 Hz to 20 kHz).
- The ripple rejection is measured at $R_S = 0$ and $f = 100$ Hz to 20 kHz, at a ripple voltage of 200 mV. With symmetrical power supplies, the ripple (200 mV) is applied in phase to the positive and the negative supply rails. With asymmetrical power supplies, the ripple rejection is measured at $f = 1$ kHz.
- $V_P = 8$ V; $R_L = 8 \Omega$; $T_{amb} = 25$ °C; $f = 1$ kHz; asymmetrical power supply. See Fig.5
- $\pm V_P = 12$ V; $R_L = 8 \Omega$; $T_{amb} = 25$ °C; $f = 1$ kHz; symmetrical power supply $I_{MUTE} < 30 \mu A$. See Fig.4
- The internal network at pin 2 is a resistor divider of typical 4 k Ω and 5 k Ω to the positive supply rail. At the connection of the 4 k Ω and 5 k Ω resistor a zener diode of typical 6.6 V is also connected to the positive supply rail. The spread of the zener voltage is 6.1 to 7.1 V.

6 W hi-fi audio power amplifier

TDA2614

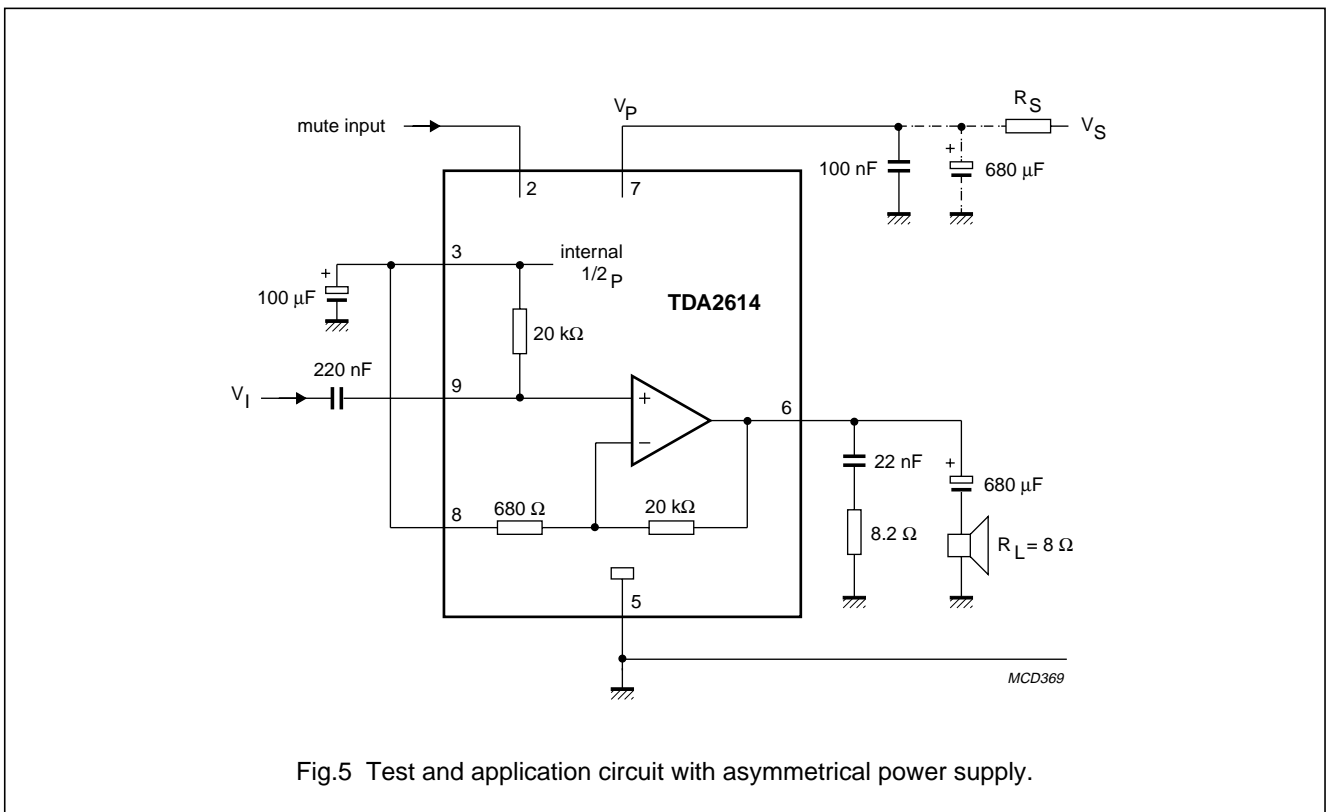
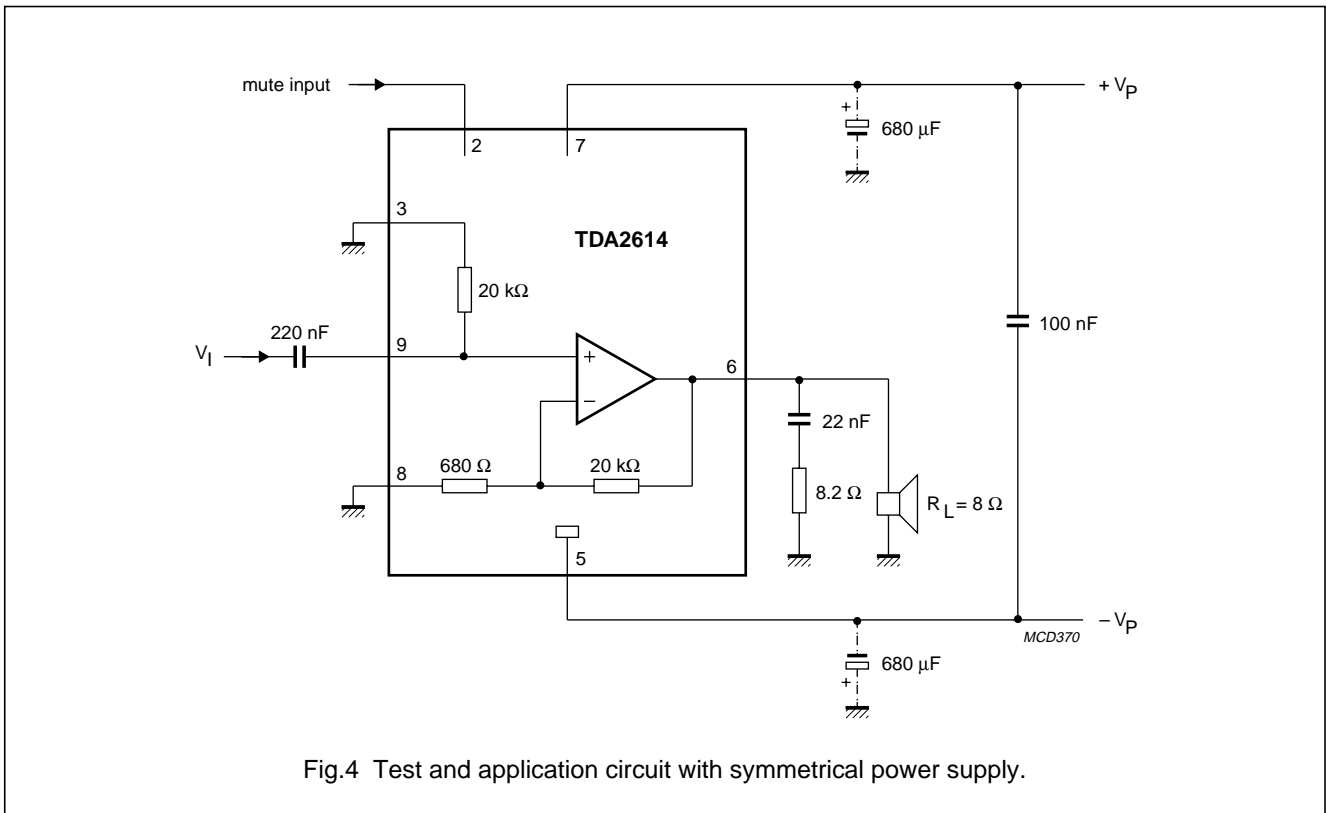

6 W hi-fi audio power amplifier

TDA2614

PACKAGE OUTLINE

SIL9MPF: plastic single in-line medium power package with fin; 9 leads

SOT110-1

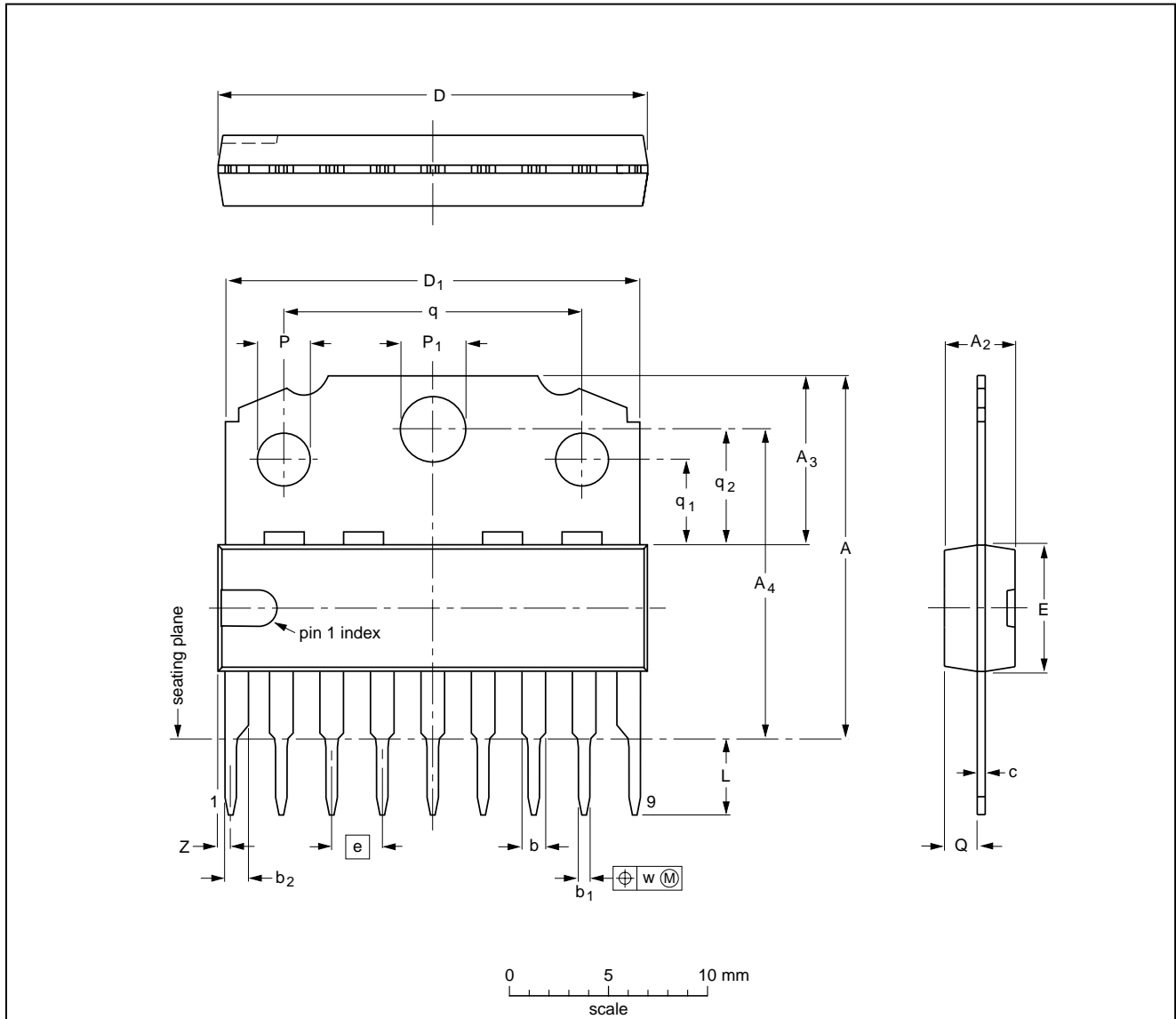

DIMENSIONS (mm are the original dimensions)

UNIT	A	A ₂ max.	A ₃	A ₄	b	b ₁	b ₂	c	D ⁽¹⁾	D ₁	E ⁽¹⁾	e	L	P	P ₁	Q	q	q ₁	q ₂	w	Z ⁽¹⁾ max.
mm	18.5 17.8	3.7	8.7 8.0	15.8 15.4	1.40 1.14	0.67 0.50	1.40 1.14	0.48 0.38	21.8 21.4	21.4 20.7	6.48 6.20	2.54	3.9 3.4	2.75 2.50	3.4 3.2	1.75 1.55	15.1 14.9	4.4 4.2	5.9 5.7	0.25	1.0

Note

1. Plastic or metal protrusions of 0.25 mm maximum per side are not included.

OUTLINE VERSION	REFERENCES				EUROPEAN PROJECTION	ISSUE DATE
	IEC	JEDEC	EIAJ			
SOT110-1						92-11-17 95-02-25

6 W hi-fi audio power amplifier

TDA2614

SOLDERING**Introduction**

There is no soldering method that is ideal for all IC packages. Wave soldering is often preferred when through-hole and surface mounted components are mixed on one printed-circuit board. However, wave soldering is not always suitable for surface mounted ICs, or for printed-circuits with high population densities. In these situations reflow soldering is often used.

This text gives a very brief insight to a complex technology. A more in-depth account of soldering ICs can be found in our "IC Package Databook" (order code 9398 652 90011).

Soldering by dipping or by wave

The maximum permissible temperature of the solder is 260 °C; solder at this temperature must not be in contact with the joint for more than 5 seconds. The total contact time of successive solder waves must not exceed 5 seconds.

The device may be mounted up to the seating plane, but the temperature of the plastic body must not exceed the specified maximum storage temperature ($T_{stg\ max}$). If the printed-circuit board has been pre-heated, forced cooling may be necessary immediately after soldering to keep the temperature within the permissible limit.

Repairing soldered joints

Apply a low voltage soldering iron (less than 24 V) to the lead(s) of the package, below the seating plane or not more than 2 mm above it. If the temperature of the soldering iron bit is less than 300 °C it may remain in contact for up to 10 seconds. If the bit temperature is between 300 and 400 °C, contact may be up to 5 seconds.

DEFINITIONS

Data sheet status	
Objective specification	This data sheet contains target or goal specifications for product development.
Preliminary specification	This data sheet contains preliminary data; supplementary data may be published later.
Product specification	This data sheet contains final product specifications.
Limiting values	
Limiting values given are in accordance with the Absolute Maximum Rating System (IEC 134). Stress above one or more of the limiting values may cause permanent damage to the device. These are stress ratings only and operation of the device at these or at any other conditions above those given in the Characteristics sections of the specification is not implied. Exposure to limiting values for extended periods may affect device reliability.	
Application information	
Where application information is given, it is advisory and does not form part of the specification.	

LIFE SUPPORT APPLICATIONS

These products are not designed for use in life support appliances, devices, or systems where malfunction of these products can reasonably be expected to result in personal injury. Philips customers using or selling these products for use in such applications do so at their own risk and agree to fully indemnify Philips for any damages resulting from such improper use or sale.